

PROJECT DESCRIPTION

An Onsite Wastewater Treatment System (OWTS) specifying supplemental treatment using AdvanTex technology is proposed to serve new development of a church and multi-purpose building to be constructed at the northeast corner of Piery Road and Tennant Avenue, San Jose in Santa Clara County, California. The proposed system is an "alternative" system with pressurized, chambered trenches which is required to address the limited suitable dispersal area and soil conditions on the subject property.

The facility will have a maximum of 11 employees working on the property at any given time from 9am-5pm, with the greatest number of employees present on Sundays to support church services. During the weekdays (Monday - Thursday), a maximum of 50 people are expected to be on the property at any given time for bible study, youth group, music rehearsals, etc. on a rotating schedule from 6:30pm-9pm. The weekends are expected to have the highest (peak) use with two church services on Sunday each with 375 people attending (total 750 people) from 9am-3pm. Occasionally there will be weddings, funerals, holidays and other events held on Saturdays typically not exceeding 50 people.

MON-SUN: 11 EMPLOYEES x 15 GPD/PERSON = 165 GPD
 MON-SAT: 50 PEOPLE x 5 GPD/PERSON = 250 GPD
 SUNDAY: 2 SERVICES x 375 PEOPLE EACH = 750 PEOPLE x 5 GPD/PERSON = 3,750 GPD

AVERAGE FLOW ATTENUATED OVER 5 DAYS:
 (3,750 GPD FOR SUNDAY) + (250 GALLONS x 6 DAYS) + (165 GALLONS x 7 DAYS) = 6,405 GAL
 6,405 GAL / 5 DAYS = 1,281 GPD ATTENUATED FLOW TO ADVANTEX AND DRAINFIELD

DRAINFIELD SIZING CALCULATIONS

11 EMPLOYEES H 15 GPD = 165 GPD
 SUNDAY 2 SERVICES H 375 PEOPLE: 750 PEOPLE H 5 GPD = 3,750 GPD
 MON-SAT: 50 PEOPLE H 5 GPD = 250 GPD
AVERAGE FLOW ATTENUATED OVER 5 DAYS:
 (3,750 GPD FOR SUNDAY) + (250 GALLONS H 6 DAYS) + (165 GALLONS H 7 DAYS) = 6,405 GAL
 6,405 GAL / 5 DAYS = 1,281 GPD ATTENUATED FLOW

TOTAL DESIGN FLOW = 1,281 GPD ATTENUATED FLOW
 AVG ADJ STABILIZED PERC RATE = 30 MPI
 30 MPI = 1.12 GAL/SF APPLICATION RATE (FOR ENHANCED TREATMENT)

1,281 GPD / 1.12 GPD/SF = 1,144 SF
 1,144 SF / 4 SF/TF = 288 LF OF TRENCH REQUIRED
288 LF = 72 INFILTRATOR CHAMBERS PROPOSED
 288 LF (PRIMARY) + 288 LF (SECONDARY) = 576 LF OF TRENCH
 72 INFILTRATORS (PRIMARY) + 72 INFILTRATORS (SECONDARY) = 144 INFILTRATORS TOTAL

PRIMARY AND SECONDARY DRAINFIELDS, EACH CONSISTING OF 3 FT-WIDE TRENCHES WITH A TOTAL DEPTH OF 4.5 FT (SEE DETAIL). EACH DRAINFIELD SHALL BE COMPOSED OF 72 QUICK4 PLUS HIGH-CAPACITY INFILTRATOR CHAMBERS FOR A TOTAL OF 288 LF OF TRENCH PER ZONE. TOTAL: 144 CHAMBERS / 576 LF TRENCHES SHALL BE SPACED 6 FT ON CENTER

NOTES:

1. ONSITE WASTEWATER TREATMENT SYSTEM TANK WITH ATTENUATION CHAMBER, ADVANTEX 100 SUPPLEMENTAL TREATMENT COMPONENTS AND DISCHARGE/DOSING CHAMBER
2. PRESSURE TRANSPORT LINE AND FLOW METER (SEE DETAIL).
3. DIVERSION VALVE BOX WITH PRESSURE GAUGE AND TWO BALL VALVES (SEE DETAIL).
4. INFILTRATOR DRAINFIELD TRENCH SHUT-OFF VALVE: HIGH-PRESSURE GATE VALVE WITH PRESSURE LATERAL CLEANOUT AND 4" CAPPED TRENCH INSPECTION RISER PIPE IN A 10"-ROUND VALVE BOX (TYP).
5. PRIMARY AND SECONDARY OWTS DRAINFIELD ZONES EACH CONSISTING OF TRENCHES WITH A 1" PRESSURIZED PVC LATERAL WITH 1/8" ORIFICES SPACED 5 FT APART. TRENCHES SHALL BE 3 FT WIDE, 4.5 FT DEEP AND SHALL BE SPACED 3 FT EDGE TO EDGE. EACH DRAINFIELD SHALL CONSIST OF 72 QUICK4 PLUS HIGH-CAPACITY INFILTRATOR CHAMBERS FOR A TOTAL OF 288 LF OF TRENCH IN EACH DRAINFIELD. (TOTAL: 144 CHAMBERS / 576 LF)
6. INFILTRATOR DRAINFIELD TRENCH END RISER: PRESSURE LATERAL FLUSHING BALL VALVE AND 4" CAPPED TRENCH INSPECTION RISER PIPE IN A 10"-ROUND VALVE BOX
7. 7.5'-DEEP INSPECTION WELL 3X (TYP)

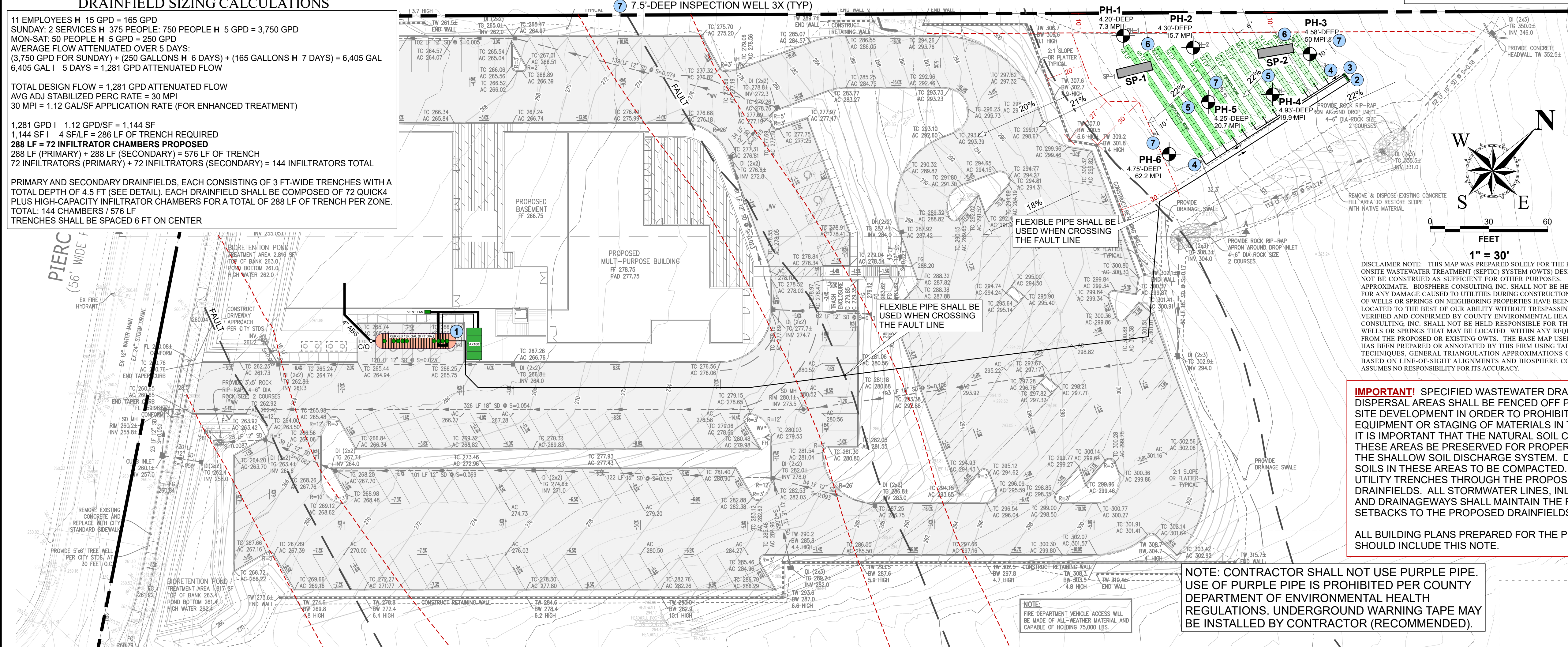
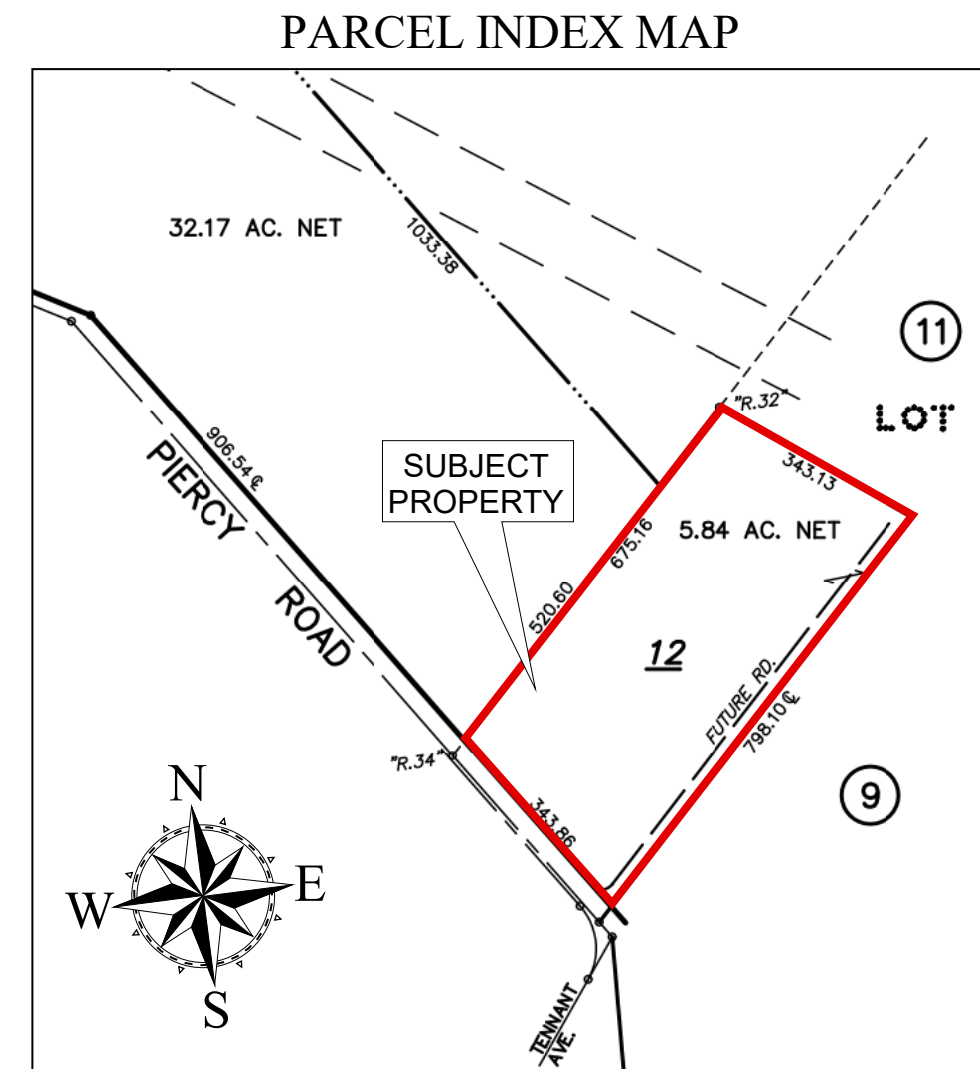
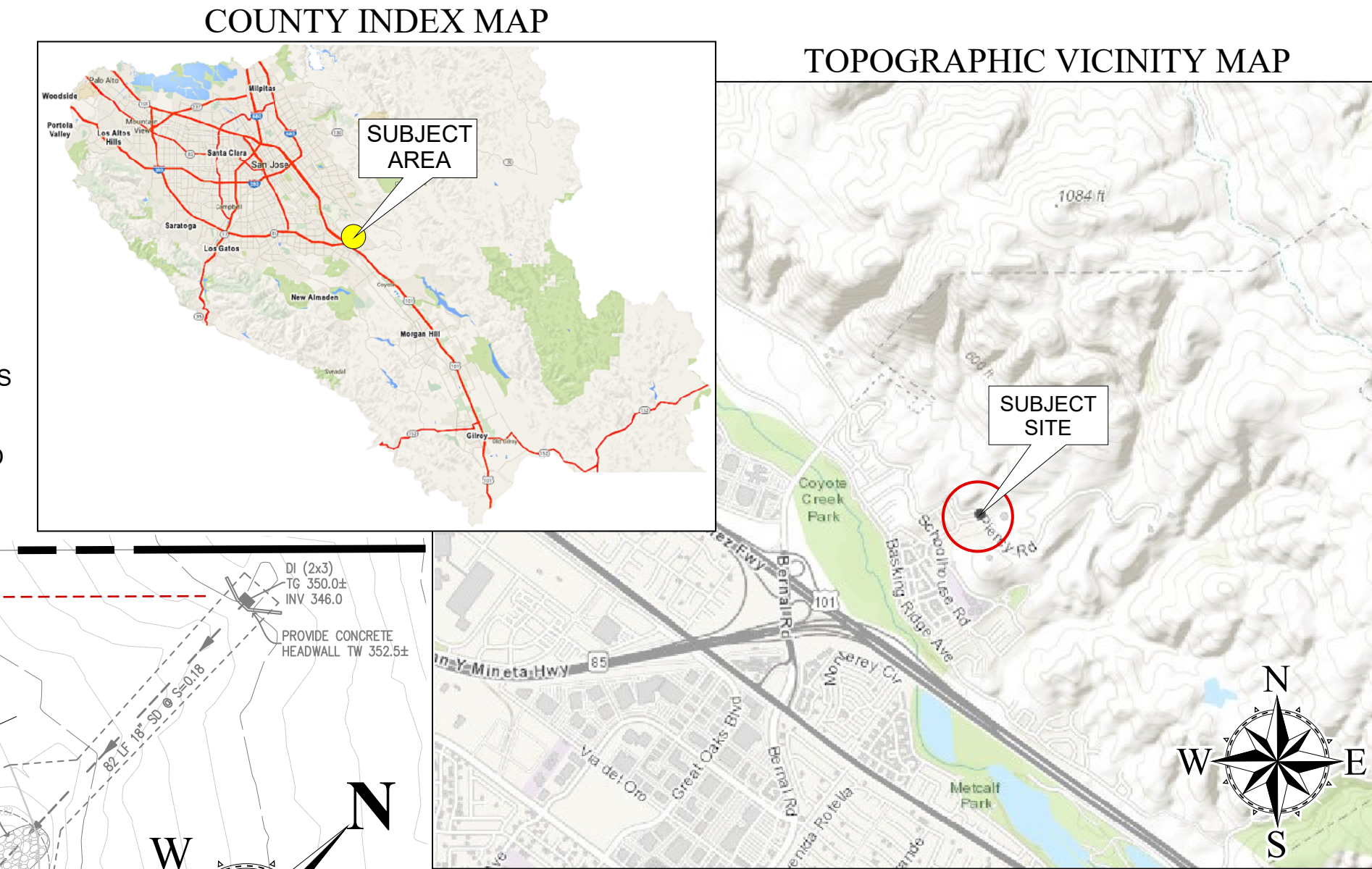

DISCLAIMER NOTE: THIS MAP WAS PREPARED SOLELY FOR THE PURPOSES OF THE ONSITE WASTEWATER TREATMENT (SEPTIC) SYSTEM (OWTS) DESIGN AND SHOULD NOT BE CONSTRUED AS SUFFICIENT FOR OTHER PURPOSES. LOCATIONS ARE APPROXIMATE. BIOSPHERE CONSULTING, INC. SHALL NOT BE HELD RESPONSIBLE FOR ANY DAMAGE CAUSED TO UTILITIES DURING CONSTRUCTION. THE LOCATION OF WELLS OR SPRINGS ON NEIGHBORING PROPERTIES HAVE BEEN IDENTIFIED AND LOCATED TO THE BEST OF OUR ABILITY WITHOUT TRESPASSING AND SHALL BE VERIFIED AND CONFIRMED BY COUNTY ENVIRONMENTAL HEALTH. BIOSPHERE CONSULTING, INC. SHALL NOT BE HELD RESPONSIBLE FOR THE LOCATIONS OF WELLS OR SPRINGS THAT MAY BE LOCATED WITHIN ANY REQUIRED SETBACKS FROM THE PROPOSED OR EXISTING OWTS. THE BASE MAP USED ON THIS SHEET HAS BEEN PREPARED OR ANNOTATED BY THIS FIRM USING TAPE AND COMPASS TECHNIQUES, GENERAL TRIANGULATION APPROXIMATIONS OR ESTIMATIONS BASED ON LINE-OF-SIGHT ALIGNMENTS AND BIOSPHERE CONSULTING, INC. ASSUMES NO RESPONSIBILITY FOR ITS ACCURACY.

IMPORTANT! SPECIFIED WASTEWATER DRAINFIELD DISPERSAL AREAS SHALL BE FENCED OFF PRIOR TO ANY SITE DEVELOPMENT IN ORDER TO PROHIBIT ANY GRADING EQUIPMENT OR STAGING OF MATERIALS IN THESE AREAS. IT IS IMPORTANT THAT THE NATURAL SOIL CONDITIONS IN THESE AREAS BE PRESERVED FOR PROPER FUNCTION OF THE SHALLOW SOIL DISCHARGE SYSTEM. DO NOT ALLOW SOILS IN THESE AREAS TO BE COMPACTED. DO NOT ROUTE UTILITY TRENCHES THROUGH THE PROPOSED DRAINFIELDS. ALL STORMWATER LINES, INLETS/OUTLETS AND DRAINAGEWAYS SHALL MAINTAIN THE REQUIRED DEH SETBACKS TO THE PROPOSED DRAINFIELDS.

ALL BUILDING PLANS PREPARED FOR THE PROJECT SHOULD INCLUDE THIS NOTE.

NOTE: CONTRACTOR SHALL NOT USE PURPLE PIPE. USE OF PURPLE PIPE IS PROHIBITED PER COUNTY DEPARTMENT OF ENVIRONMENTAL HEALTH REGULATIONS. UNDERGROUND WARNING TAPE MAY BE INSTALLED BY CONTRACTOR (RECOMMENDED).

COUNTY E.H. ACCEPTANCE/APPROVAL STAMPS

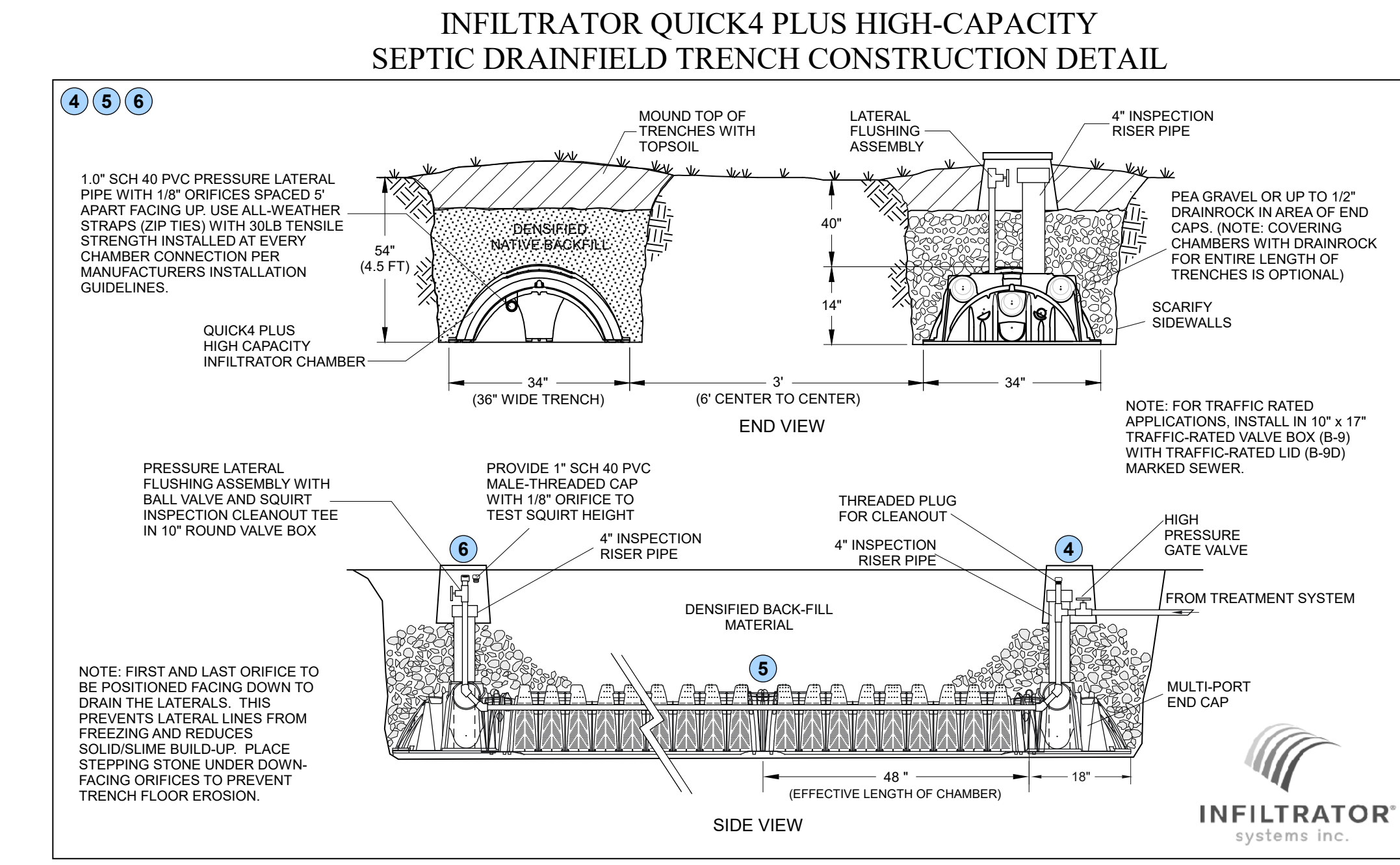
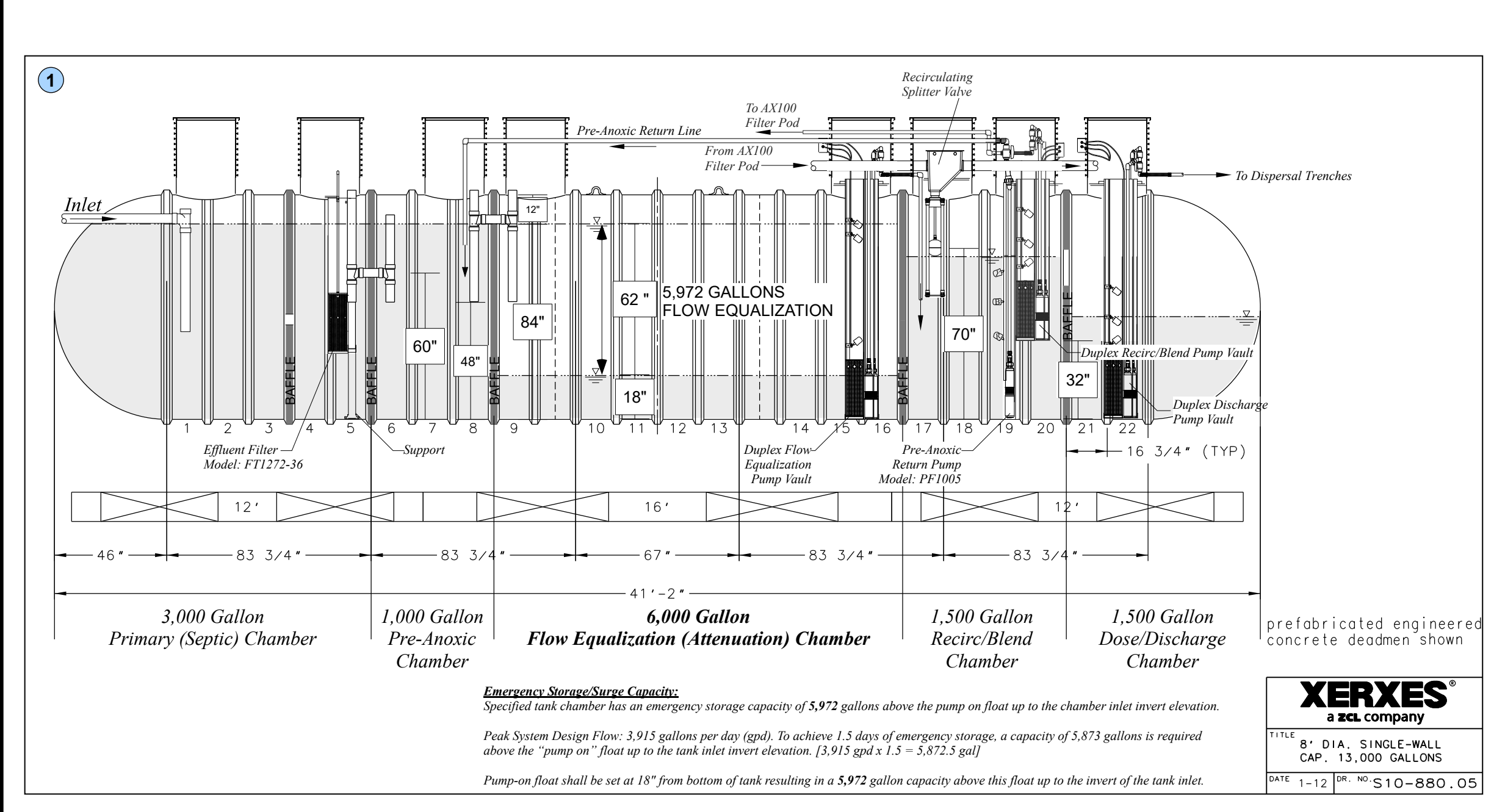

BioSphere Consulting
 Alternative Wastewater System Design
 1315 King Street, Santa Cruz, CA 95060
 Tel: (831) 430-9116
 www.biosphere-consulting.com

- Site Evaluation & Mapping
- Soil Analysis & Percolation Testing
- New Development, Upgrade & Repairs
- Residential & Commercial

| ONSITE WASTEWATER TREATMENT SYSTEM DESIGN PLAN | | | |
|--|--|-----------------|--------------------------------------|
| Project Location: | 0 Piery Road in San Jose, California, [Santa Clara County] | Property Owner: | Southridge Church C/o: Micaiah Imler |
| Mailing Address: | 6830 Via Del Oro, Suite 250 San Jose, CA, 95119 | Owner Phone #: | (408) 728-7471 |
| Date: | 03/08/23 | By: | David Quinn / Andrew Brownstone |
| REVISION: | 10/30/23 | Job No.: | 22021 |
| | | APN: | 678-13-012 |
| | | Sheet: | 1 OF 3 |

THE USE OF THESE PLANS AND SPECIFICATIONS SHALL BE RESTRICTED TO THE ORIGINAL SITE FOR WHICH THEY WERE PREPARED AND PUBLICATION OR REPRODUCTION OF ANY METHOD, IN WHOLE OR IN PART, IS PROHIBITED. BIOSPHERE CONSULTING, INC. MAINTAINS TITLE OWNERSHIP OF THE PLANS AND SPECIFICATIONS WITHOUT PRECEDENCE. VISUAL CONTACT WITH THESE PLANS AND SPECIFICATIONS SHALL CONSTITUTE FRAUDULENT CONDUCT AND SHALL BE PROSECUTED TO THE FULL EXTENT OF THE LAW.

TANK AND ADVANTEX AX100 FILTER POD DETAIL

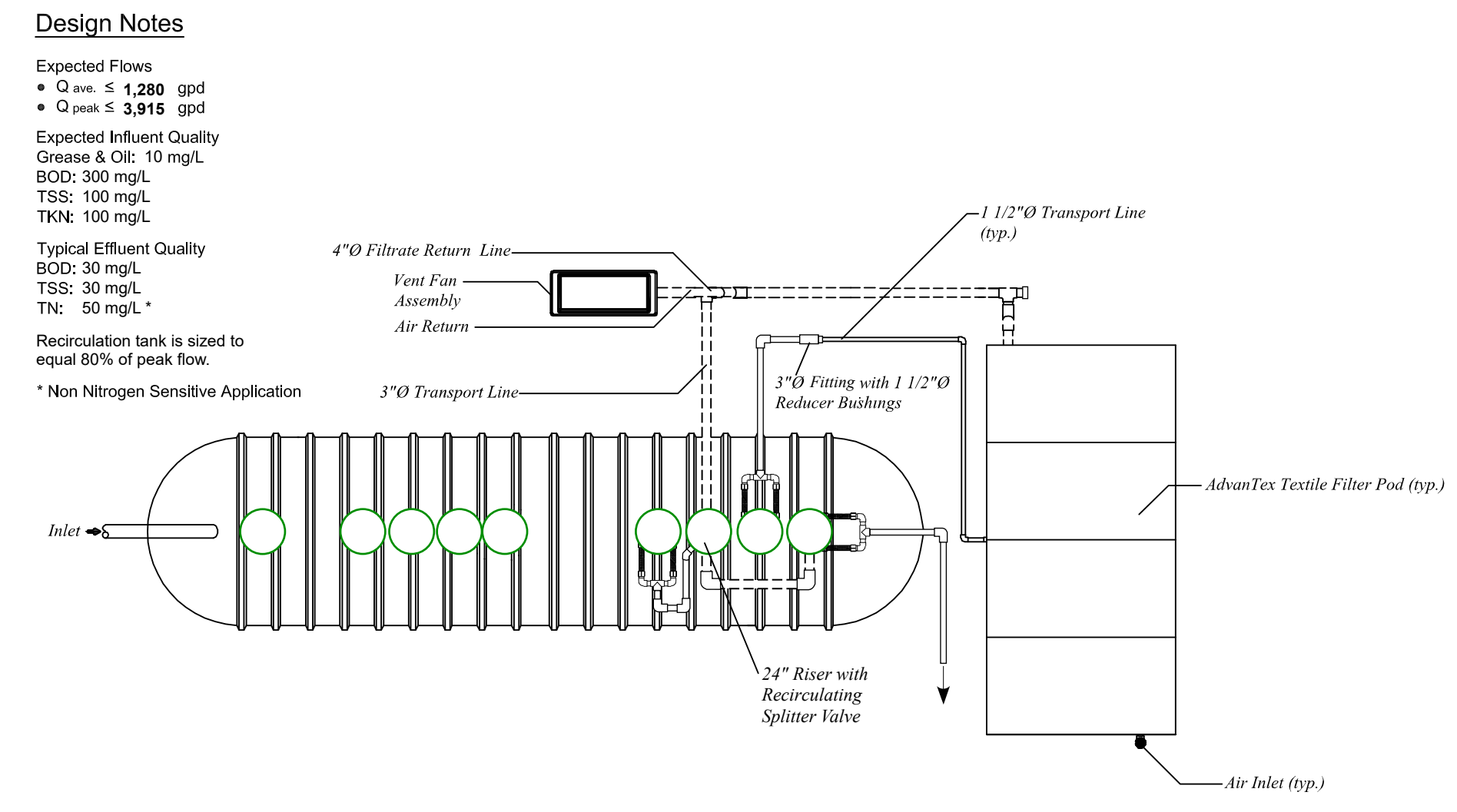

AX100 FILTER POD CROSS-SECTION DETAIL

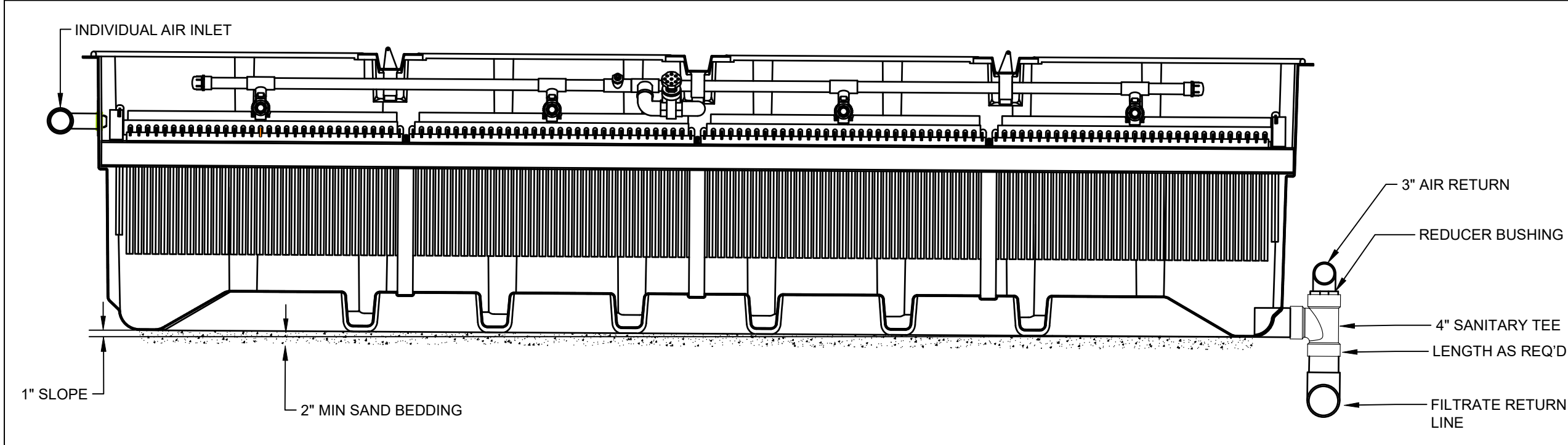

PUMP SELECTION CHART

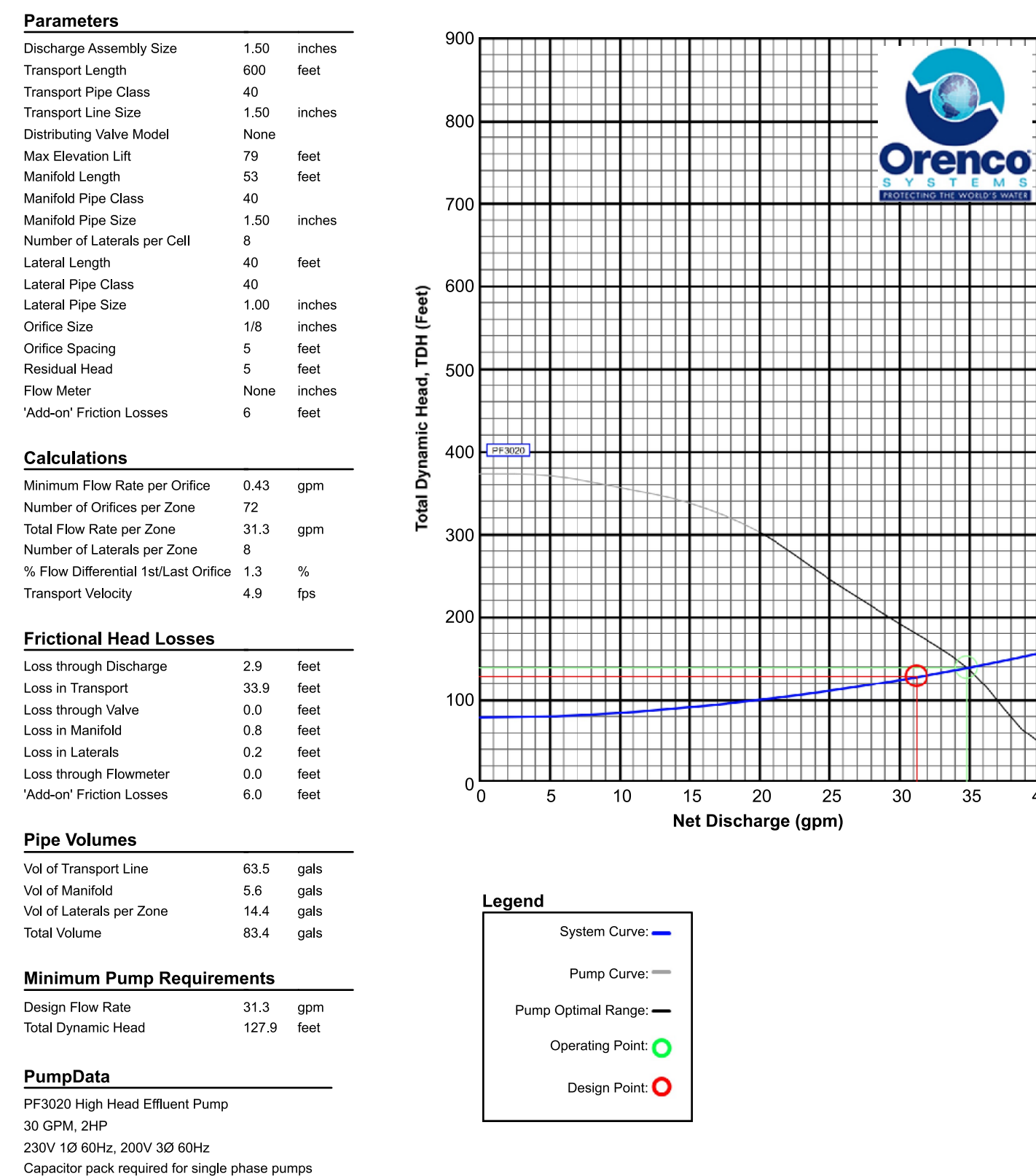

AX100 FILTER POD FILTRATE RETURN LINE ISO

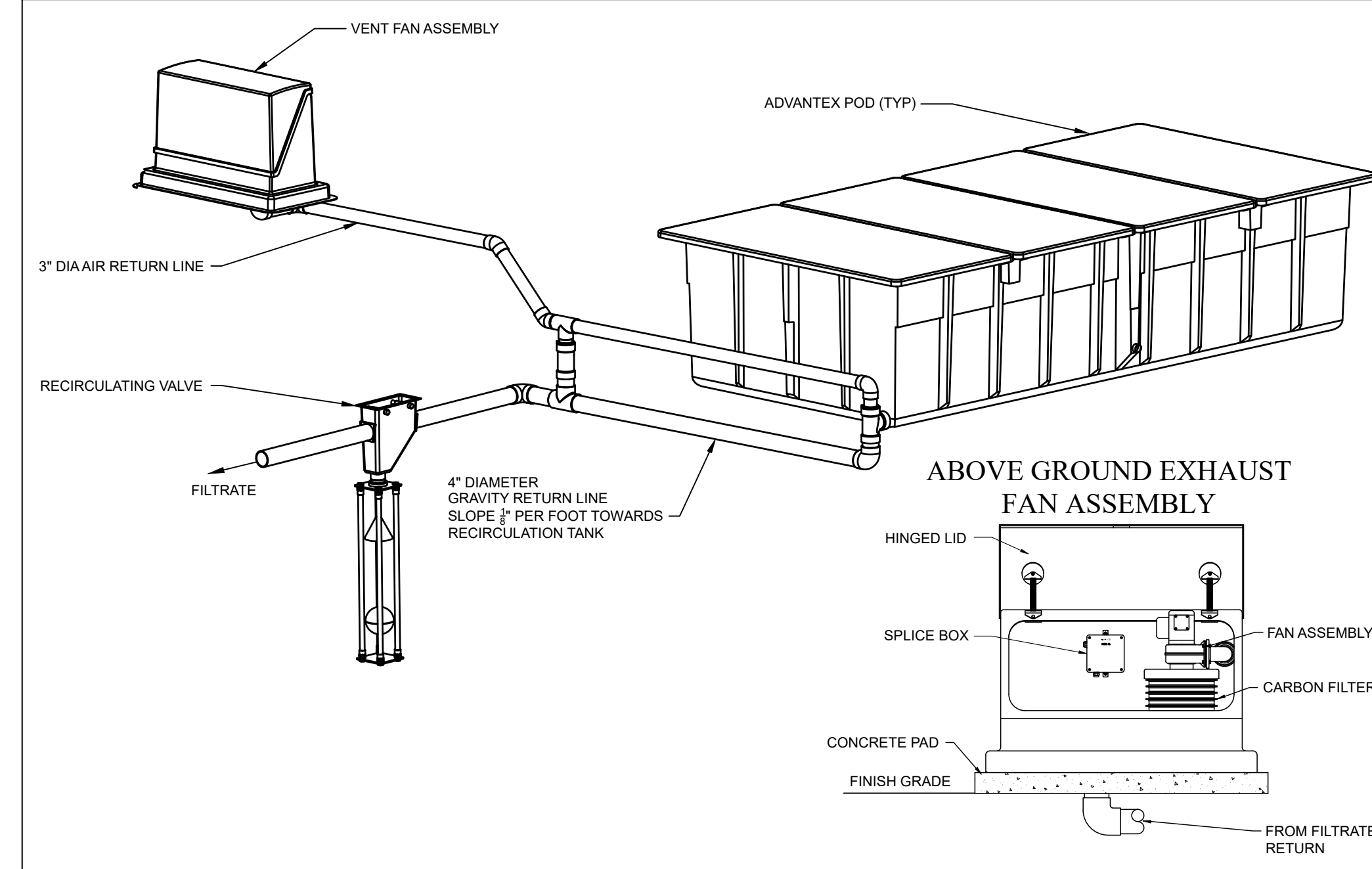

VALVE BOX DETAIL

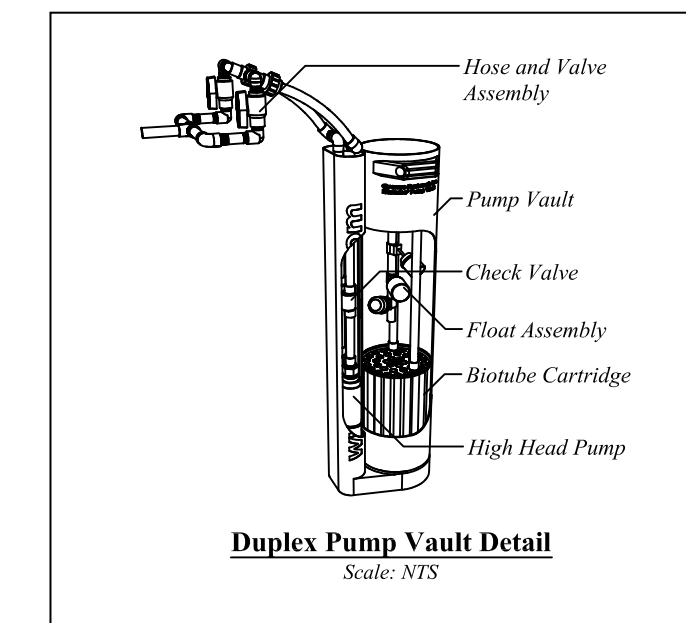
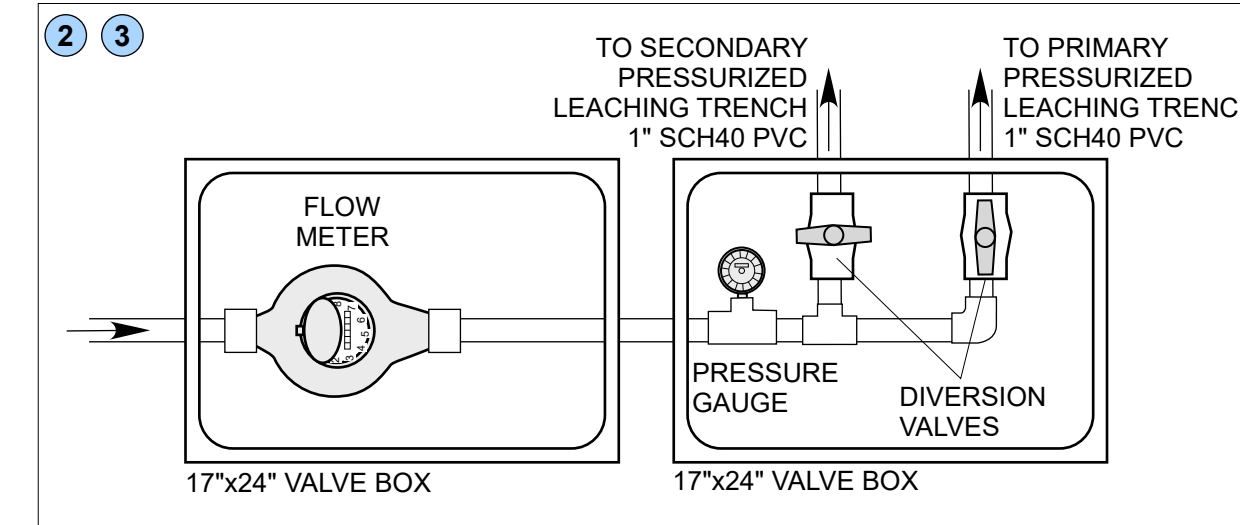

XERXES TANK BURIAL DETAIL

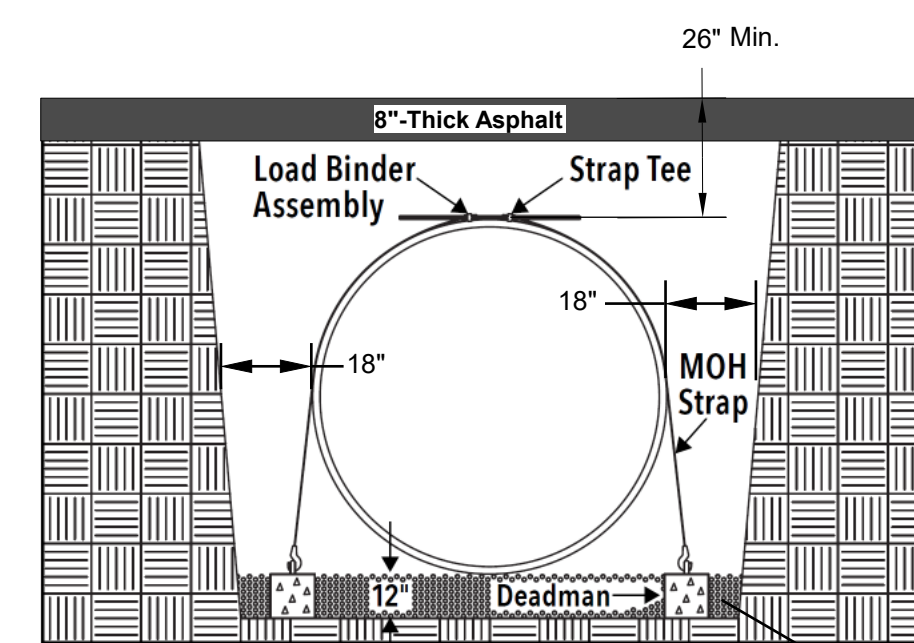

BACKFILL (BEDDING) MATERIAL (ROUNDED OR CRUSHED STONE) PER APPENDIX C IN INSTALLATION MANUAL

CONSTRUCTION & DESIGN CRITERIA

- The proposed Onsite Wastewater Treatment System (OWTS) is designed to an attenuated wastewater design flow of 1,281 Gallons Per Day (GPD) per County DEH guidelines. The AdvanTex™ wastewater treatment system can accommodate occasional maximum flows up to 3,915 GPD
- Soil Profile test-pits did not exhibit any evidence of seasonally high groundwater conditions. Seasonally high groundwater is estimated to occur at greater than 14' below grade.
- Soil percolation testing resulted in an average stabilized adjusted percolation rate of 29.28 Minutes Per Inch.
- No wells, springs or watercourses are situated within 100' of the proposed OWTS.

TABLE PD-3. SHALLOW PRESSURE DISTRIBUTION SYSTEM MANAGEMENT REQUIREMENTS

| WORK | FREQUENCY |
|--|--|
| <ul style="list-style-type: none"> Conduct routine visual observations of disposal field and downslope area and surroundings for wet areas, pipe leaks or damage, soil erosion, drainage issues, abnormal vegetation, gophers or other problems. Perform inspections of pump and appurtenances (per O&M manual and Performance Evaluation Guidelines, Part 5 of this Manual). | <ul style="list-style-type: none"> Every 6 to 12 months. |
| <ul style="list-style-type: none"> Purge laterals, squirt and balance. Exercise valves to ensure functionality. Perform all maintenance work as recommended by equipment manufacturer for any special valves or other components. Investigate and repair erosion, drainage or other disposal field problems, as needed. Investigate and perform distribution system corrective work, as required. Record work done. | <ul style="list-style-type: none"> Distribution system maintenance annually. Other maintenance as required. |
| <ul style="list-style-type: none"> Measure and record water levels in trench observation wells. Measure and record water levels in dispersal field monitoring wells, as applicable, per permit requirements. Obtain and analyze water samples from monitoring wells, as applicable, per permit requirements. Report findings to DEH per permit requirements. Standard report to include dates, observation well and monitoring well readings and other data collected, work performed, corrective actions taken, and performance summary. Report public health/water quality emergency to DEH immediately. | <ul style="list-style-type: none"> Measure trench water levels annually. Other monitoring according to permit conditions, as applicable. According to permit conditions, typically every 1 to 2 years, depending on systems size, usage, history, location. |
| <ul style="list-style-type: none"> Reporting | <ul style="list-style-type: none"> Reporting |

SYSTEM OPERATION AND MAINTENANCE

- The owner should read and operate the system according to the AdvanTex™ operation and maintenance literature.
- Oreco requires biannual maintenance servicing of the AdvanTex™ by a qualified technician.
- County Environmental Health will issue an OWTS Annual Operating Permit and requires that the property owner maintain a system service agreement/contract with a qualified third-party service provider. This requirement will be placed on the title deed for the property.
- The treatment tank is alive with important microorganisms. Do not add any materials (paint thinner, paint, motor oil, unused medicine, etc.) that may disrupt the biologic treatment process. The primary tank should be pumped when the total of the scum/sludge thickness is greater than 1/3 of the total liquid level depth.
- DO NOT ROUTE WATER SOFTENER BACKFLUSH DISCHARGE TO TREATMENT SYSTEM! This discharge may be routed directly to a drainfield trench or an approved dispersal field.
- Repair all plumbing leaks (especially toilet leaks) promptly.

SOIL PERCOLATION SUMMARY TABLE -- 09/15/22

| Percolation Hole (PH) | 1 | 2 | 3 | 4 | 5 | 6 | |
|--------------------------|---------------------|-------|-----------------|-------|-----------------|-------|-------|
| Depth | 4.20' | 4.30' | 4.58' | 4.93' | 4.25' | 4.75' | |
| Stabilized MPI | R | 5.20 | 11.20 | 35.70 | 14.20 | 14.80 | |
| Adjusted Stabilized MPI | R | 7.28 | 15.68 | 49.98 | 19.88 | 20.72 | |
| Avg. Adj. Stabilized MPI | R | | | | | | 29.28 |
| # Bedrooms: | FOR OFFICE USE ONLY | | TANK SIZE (Gal) | | Leach Line (Ft) | | |

COUNTY E.H. ACCEPTANCE/APPROVAL STAMPS

BioSphere Consulting
 Alternative Wastewater System Design
 1315 King Street Santa Cruz, CA 95060
 Tel: (831) 430-9116
 www.biosphere-consulting.com

- Site Evaluation & Mapping
- Soil Analysis & Percolation Testing
- New Development, Upgrade & Repairs
- Residential & Commercial

ONSITE WASTEWATER TREATMENT SYSTEM DESIGN PLAN

| | |
|---------------------------|---|
| Project Location: | 0 Piercy Road in San Jose, California, [Santa Clara County] |
| Property Owner: | Southridge Church C/o: Micaiah Imler |
| Mailing Address: | 6830 Via Del Oro, Suite 250 San Jose, CA, 95119 |
| Owner Phone #: | (408) 728-7471 |
| Date: 03/08/23 | By: David Quinn / Andrew Brownstone |
| REVISION: 10/30/23 | Job No.: 22021 APN: 678-13-012 |



SPECIFICATIONS

1. SEWER LINE COLLECTION SYSTEM

- 1.1. PROPERLY VENTED 4" BUILDING SEWER TIGHT LINES SHALL BE INSTALLED CONNECTING ALL FACILITY WASTEWATER DRAINS TO THE PROPOSED PRIMARY WASTEWATER PROCESSING TANK (SEE SHEET 3 & 4). ALL GRAVITY FLOW WASTEWATER PIPING MUST MAINTAIN A MINIMUM 2% CONTINUOUS GRADIENT. ANY SECTIONS OF PIPE USED TO TRANSPORT WASTEWATER THAT CANNOT MEET THE MINIMUM 12" SEPARATION REQUIREMENT BELOW WATER SUPPLY PIPE LINES AT CROSSINGS SHALL BE INSTALLED WITH NO JOINTS WITHIN TEN FEET FROM EITHER SIDE OF THE WATER MAIN AND SHALL BE CONSTRUCTED OF HDPE PIPE WITH FUSION-WELDED JOINTS OR THE WATER PIPE LINE SHALL BE SLEEVED. ALL WASTEWATER INCLUDING GRAYWATER FROM FACILITY SHALL BE DISCHARGED TO THE PROCESSING TANKS. WATER SOFTENER BRINE BACK-FLUSH DISCHARGE SHALL NOT BE ROUTED TO THE TREATMENT SYSTEM TANKS.
- 1.2. INSTALLATION OF ALL GRAVITY FLOW SANITARY SEWER LINES SHALL BE FULLY COORDINATED WITH INSTALLATION OF OTHER SITE STORM/UNDER DRAINS AND UTILITY TRENCHES PER CURRENT PROJECT CIVIL PLANS.

2. PRIMARY, ATTENUATION, RECIRC/PROCESSING AND DISCHARGE TANK (6 CHAMBERS)

- 2.1. 13,000 GALLON, WATERTIGHT, FIBERGLASS REINFORCED POLYESTER (FRP) TANK FROM XERXES®, CORPORATION, OR APPROVED EQUAL. THE TANK SHALL HAVE SIX CHAMBERS SEPARATED BY BAFFLES. THE FIRST FOUR CHAMBERS SHALL SERVE AS A PRIMARY SEPTIC TANK/CHAMBER (3,000 GAL), PRE-ANOXIC TANK/CHAMBER (1,000 GAL) AND FLOW-EQUALIZATION (ATTENUATION) TANK/CHAMBER (6,000 GAL). THE FINAL TWO CHAMBERS SHALL BE ISOLATED WITH SOLID BAFFLES THAT DO NOT HAVE A PASS-THROUGH. THESE TWO CHAMBERS SHALL SERVE AS A PROCESSING/RECIRC BLEND TANK/CHAMBER (1,500 GAL) WITH THE PROPOSED ADVANTEX TREATMENT SYSTEM AND A DOSING TANK/CHAMBER (1,500) FOR THE DISCHARGE OF TREATED FILTRATE. (SEE DETAIL)
- 2.2. THE TANKS/CHAMBERS SHALL BE INSTALLED IN STRICT ACCORDANCE WITH THE MANUFACTURER'S GUIDELINES OUTLINED IN THE CURRENT MANUFACTURER'S INSTALLATION MANUAL.
- 2.3. AN ORENCO SYSTEMS, INC. (OSI) DUAL EFFLUENT FILTER (MODEL NUMBER: FT1566-36R) OR APPROVED EQUAL SHALL BE INSTALLED AT THE OUTLET OF THE SECOND BAFFLED CHAMBER.
- 2.4. XERXES-SUPPLIED PREFABRICATED 12"X12" DEADMEN OR APPROVED EQUAL SHALL BE INSTALLED ALONG THE ENTIRE LENGTH OF BOTH SIDES OF THE TANK. DEADMEN SHALL BE INSTALLED IN THE EXCAVATION PARALLEL TO THE TANK AND OUTSIDE THE TANK "SHADOW." HOLD-DOWN CABLE STRAPS AND MOH ANCHORING HARDWARE FROM DEADMEN MANUFACTURER SHALL BE USED AND INSTALLED ACCORDING TO THE MANUFACTURER'S INSTALLATION MANUAL. PROPER ANTI-BOUYANCY ANCHORING OF TANKS IS CRITICAL.
- 2.5. ALL TANK ACCESS RISERS SHALL BE 24"-30" IN DIAMETER AND CONSTRUCTED WATERTIGHT. RISER INSTALLATION SHALL BE ACCOMPLISHED ACCORDING TO THE MANUFACTURER'S INSTRUCTIONS. THE RISERS SHALL BE ATTACHED TO THE TANKS SUCH THAT A WATERTIGHT SEAL IS PROVIDED. ADHESIVE REQUIRED TO ADHERE THE PVC OR FIBERGLASS RISERS TO EITHER FIBERGLASS OR ABS TANK ADAPTER SHALL BE A TWO-PART ADHESIVE, MODEL MA320, SS115, SS140 OR APPROVED EQUAL, OR A SINGLE COMPONENT ADHESIVE MODEL ADH100 OR APPROVED EQUAL, OR A COMBINATION OF BOTH IF BACK-FILLING THE SAME DAY IS DESIRED. TO ENSURE PRODUCT COMPATIBILITY, A SINGLE MANUFACTURER SHALL SUPPLY RISERS, LIDS, AND ATTACHMENT COMPONENTS.
- 2.6. ORENCO SYSTEMS, INC. EPDM GASKETS, OR APPROVED EQUAL, SHALL BE USED AT THE INLET TO JOIN THE TANK WALL AND THE INLET PIPING. ABS OR SCHEDULE 40 PVC PIPE AND FITTINGS SHALL BE USED AT THE INLETS.
- 2.7. INLET PLUMBING SHALL INCLUDE AN INLET TEE THAT PENETRATES 18-INCHES INTO THE LIQUID FROM THE INLET FLOW LINE. THE DEPTH MAY VARY DEPENDING ON THE TANK'S HEIGHT; IN ALL CASES, THOUGH, THE INLET SHOULD EXTEND TO A LEVEL BELOW THE BOTTOM OF THE MAXIMUM SCUM DEPTH. THE INLET PLUMBING SHALL ALLOW FOR NATURAL VENTILATION BACK THROUGH THE BUILDING SEWER AND VENT STACK.
- 2.8. IN ORDER TO DEMONSTRATE WATERTIGHTNESS, TANKS SHALL BE TESTED ON-SITE PRIOR TO ACCEPTANCE. AFTER INSTALLATION IS COMPLETED AND BEFORE BACK-FILLING, COMPLETELY FILL THE TANK WITH WATER, TO A LEVEL TWO (2) INCHES INTO THE RISER. WAIT A MINIMUM OF TWO (2) HOURS (OR AS REQUIRED BY LOCAL REQUIREMENTS) AND INSPECT THE TANK FOR LEAKS. THERE SHOULD BE NO DROP IN LIQUID LEVEL AND NO VISUAL LEAKAGE FROM SEAMS, PINHOLES, OR OTHER IMPERFECTIONS. OBTAIN A WATERTIGHT TANK INSPECTION BY DEH AND THE DESIGNER OR DISTRIBUTOR WITH 24 HOURS NOTICE. ONCE THE TANK IS PROVEN TO BE WATERTIGHT, DROP THE WATER LEVEL IN THE TANK BELOW THE INVERT – BUT NOT BELOW THE MID-SEAM.
- 2.9. TRAFFIC-RATED MANHOLE GRADE RINGS/LIDS SHALL BE INSTALLED OVER EACH TANK ACCESS RISER/LID. GRADE RINGS AND TRAFFIC LIDS SHALL BE 30"-DIAMETER H-20 TRAFFIC-RATED FROM CNI MANUFACTURING (MODEL #8039) OR APPROVED EQUAL OVER THE 24"-DIAM ACCESS RISERS AND TO 44" H-20 TRAFFIC-RATED FROM MORRISON BROS. CO. (MODEL#; 318L-4400 AMC) OR APPROVED EQUAL OVER ANY 30"-DIAM ACCESS RISERS. GRADE RINGS/LIDS MUST NOT TRANSMIT ANY TRAFFIC LOAD TO THE ATTACHED TANK ACCESS RISER. A MINIMUM SPACE OF 3 INCHES MUST EXIST BETWEEN THE BOTTOM OF THE GRADE RING LID AND THE TOP OF THE TANK ACCESS RISER LID.

3. ADVANTEX TREATMENT SYSTEM

- 3.1. THE PROPOSED ADVANTEX™ TREATMENT SYSTEM INCLUDES A RECIRCULATING SPLITTER BALL FLOAT VALVE, A BIOTUBE® DUPLEX PUMP PACKAGE FOR RECIRCULATION, AN AX-100 PACKED-BED FILTER POD, AND TELEMETRY-ENABLED CUSTOM TCOM CONTROL PANEL.
- 3.2. A 4-INCH DIAMETER **RECIRCULATING BALL VALVE ASSEMBLY** (OSI MODEL RSV4U SHALL BE INSTALLED TO PROVIDE RETURN OF TREATED EFFLUENT FROM FILTER POD. THE BALL VALVE IS DESIGNED TO REDIRECT 100% OF FLOW TO THE RECIRCULATION CHAMBER DURING PERIODS OF LOW FLOW OR 100% TO DISCHARGE TANK DURING PERIODS OF HIGH FLOW. MUST BE MANUFACTURED OF CORROSION RESISTANT PVC, FIBERGLASS, POLYETHYLENE AND ABS COMPONENTS AND ALLOW FOR EASY REMOVAL USING A SLIDING QUICK-DISCONNECT. THE ITEM IS PATENTED AND THE DESIGNER KNOWS OF NO EQUIVALENT.
- 3.3. AN OSI MODEL PVU SERIES, UNIVERSAL BIOTUBE® **PUMP VAULT** OR APPROVED EQUAL SHALL BE INSTALLED IN THE OUTLET RISER OF THE RECIRC/BLEND CHAMBER. THE FILTER SHALL HAVE A MINIMUM EFFECTIVE SCREEN AREA OF NO LESS THAN 20.6 SQUARE FEET. THE BIOTUBE PUMP VAULT SHALL CONSIST OF A 12-INCH DIAMETER POLYETHYLENE VAULT WITH EIGHT (8) 2-INCH DIAMETER HOLES EVENLY SPACED AROUND THE PERIMETER. HOUSED INSIDE THE POLYETHYLENE VAULT SHALL BE THE BIOTUBE ASSEMBLY CONSISTING OF 1/8-INCH MESH POLYPROPYLENE TUBES. A FLOW INDUCER TO ACCEPT TWO HIGH-HEAD EFFLUENT PUMPS SHALL BE ATTACHED TO THE VAULT.
- 3.4. FLOAT SWITCH ASSEMBLIES SHALL BE OSI (MODEL MF3V) OR APPROVED EQUAL WITH THREE MECHANICAL SWITCH FLOATS MOUNTED ON A PVC STEM ATTACHED TO THE FILTER CARTRIDGE. THE FLOATS MUST BE ADJUSTABLE AND MUST BE REMOVABLE WITHOUT REMOVING THE PUMP VAULT. THE HIGH/LAG- AND LOW-LEVEL ALARMS, AND OVERRIDE ON/OFF FUNCTION SHALL BE PRESET AS SHOWN IN THE DETAILS ON THIS SHEET. EACH FLOAT LEAD SHALL BE SECURED WITH A NYLON STRAIN RELIEF BUSHING AT THE SPLICE BOX. THE FLOATS SHALL BE UL OR CSA LISTED AND SHALL BE RATED FOR A MINIMUM OF 5.0 AMPS.
- 3.5. DUPLEX OSI HIGH-HEAD EFFLUENT **PUMPS** OR APPROVED EQUAL SHALL BE INSTALLED IN RECIRC/BLEND CHAMBER. PUMPS SHALL BE 1.0 HP 75 GPM SINGLE PHASE 230V, WITH EXTRA HEAVY DUTY (SO) ELECTRICAL CORD WITH GROUND. PUMP SHALL BE UL AND CSA LISTED FOR USE AS AN EFFLUENT PUMP.
- 3.6. AN OSI DISCHARGE **HOSE AND VALVE ASSEMBLY** (MODEL HV200BSX) OR APPROVED EQUAL SHALL BE INSTALLED. ASSEMBLY SHALL INCLUDE A 2-INCH, 150 PSI PVC BALL VALVE, 200 PSI PVC TRUE UNION BALL CHECK VALVE, PVC FLEX HOSE WITH MINIMUM WORKING PRESSURE RATING OF 60 PSI, AND SCHEDULE 40 PVC PIPE.
- 3.7. THE PRESSURIZED **TRANSPORT PIPE** FROM THE RECIRC. PUMPS TO THE FILTER POD SHALL BE 1.5" SCHEDULE 40 HDPE PIPE WITH FUSION-WELDED JOINTS (THIS PIPE SHALL BE LABELLED ACCORDING TO CURRENT UPC REQUIREMENTS "RECLAIMED WATER - DO NOT DRINK").
- 3.8. AX100 ADVANTEX® **FILTER POD** SHALL BE INSTALLED IN CONFORMANCE WITH THE MANUFACTURER'S GUIDELINES. THE AX100 IS A PACKED BED FILTER CONSISTING OF A PROPRIETARY TEXTILE MEDIA. THE MEDIA HAS BEEN SPECIFICALLY ENGINEERED FOR WASTEWATER APPLICATIONS. THE ITEM IS PATENTED AND THE DESIGNER KNOWS OF NO EQUIVALENT. THE BOTTOM OF THE POD SHALL BE SET NO LESS THAN 8" BELOW FINISHED GRADE AND POD LID SHALL BE INSTALLED A MIN OF 6" ABOVE FINISHED GRADE.
- 3.9. THE **GRAVITY FILTRATE RETURN PIPE** FROM THE FILTER POD TO THE RECIRC/BLEND CHAMBER AND ON TO THE DISCHARGE PUMP TANK SHALL BE 4.0" SCHEDULE 40 PVC PIPE. ASSURE CONTINUOUS FALL ON THE RETURN PIPING AS VENTING THROUGH THIS PIPE IS CRITICAL. SAGS OR BELLIES IN THIS PIPE WILL AFFECT PERFORMANCE OF TREATMENT SYSTEM THUS COMPACTED TRENCH BASE MATERIAL IS VERY IMPORTANT. (THIS PIPE SHALL BE LABELLED ACCORDING TO CURRENT UPC REQUIREMENTS "RECLAIMED WATER - DO NOT DRINK").
- 3.10. **CONTROL PANEL** SHALL BE OSI TCOM™ CONTROL PANEL OR APPROVED EQUAL WITH REMOTE TELEMETRY CONTROL/MONITORING SYSTEM WITH REAL TIME EFFICIENCY CAPABLE OF LOGGING DATA FOR SYSTEM CONDITIONS AND EVENTS. PANEL SHALL INCLUDE AUDIO ALARM PROVIDING 80 DB AT 24". VISUAL ALARM: 7/8" DIAMETER RED LENS, "PUSH-TO-SILENCE" WITH 1-WATT BULB, GROUND FAULT INTERRUPTER (GFI), CURRENT SENSOR WITH ADJUSTABLE HIGH & LOW ALARM SET POINTS. PANEL ENCLOSURE SHALL BE NEMA 4X RATED, CONSTRUCTED OF UV-RESISTANT FIBERGLASS OR NEMA 4 OR APPROVED EQUAL. REMOTE TELEMETRY UNIT TO INCLUDE ATRTU-NET; SELF POWERED 24 VDC AT 10 MA MAX, 8 DIGITAL INPUTS, 8 ANALOG INPUTS, ON-BOARD MODEM (9600 BAUD), ETHERNET PORT (10 BASE T, RJ45JACK) AND MODBUS PORT (RS422/485 TERMINALS). THE PANEL SHOULD BE INSTALLED AT A CONVENIENT HEIGHT (USUALLY ABOUT FIVE FEET ABOVE THE GROUND) AND WHERE IT WILL BE ACCESSIBLE FOR OPERATION AND MAINTENANCE.
- 3.11. THREE 30 AMP **ELECTRICAL CIRCUITS** (230V) SHALL BE EXTENDED TO THE TCOM CONTROL PANEL. A DEDICATED PHONE/DATA LINE WITH CAT6 WIRING SHALL BE INSTALLED IN A SEPARATE CONDUIT TO THE CONTROL PANEL. FOUR ELECTRICAL CIRCUITS IN UNDERGROUND CONDUITS SHALL BE INSTALLED FROM THE PANEL TO THE RECIRCULATION PUMPS AND DISCHARGE PUMPS. FOUR LOW VOLTAGE CONTROL CIRCUITS SHALL BE INSTALLED IN SEPARATE CONDUITS TO THE TWO FLOAT SWITCH ASSEMBLIES AND 13 SOLENOID ZONE/FIELD FLUSH VALVES.

4. DISCHARGE/DOSE TANK (CHAMBER) PUMPING SYSTEM

- 4.1. FLOAT SWITCH ASSEMBLIES SHALL BE OSI (MODEL MF3V) OR APPROVED EQUAL WITH THREE MECHANICAL SWITCH FLOATS MOUNTED ON A PVC STEM ATTACHED TO THE FILTER CARTRIDGE. THE FLOATS MUST BE ADJUSTABLE AND MUST BE REMOVABLE WITHOUT REMOVING THE PUMP VAULT. THE HIGH/LAG- AND LOW-LEVEL ALARMS, AND OVERRIDE ON/OFF FUNCTION SHALL BE PRESET AS SHOWN IN THE DETAILS ON THIS SHEET. EACH FLOAT LEAD SHALL BE SECURED WITH A NYLON STRAIN RELIEF BUSHING AT THE SPLICE BOX. THE FLOATS SHALL BE UL OR CSA LISTED AND SHALL BE RATED FOR A MINIMUM OF 5.0 AMPS.
- 4.2. DUPLEX OSI HIGH-HEAD EFFLUENT **PUMPS** OR APPROVED EQUAL SHALL BE INSTALLED IN RECIRC/BLEND CHAMBER. PUMPS SHALL BE 1.0 HP 75 GPM SINGLE PHASE 230V, WITH EXTRA HEAVY DUTY (SO) ELECTRICAL CORD WITH GROUND. PUMP SHALL BE UL AND CSA LISTED FOR USE AS AN EFFLUENT PUMP.
- 4.3. AN OSI DISCHARGE **HOSE AND VALVE ASSEMBLY** (MODEL HV125BSX) OR APPROVED EQUAL SHALL BE INSTALLED. ASSEMBLY SHALL INCLUDE A 1.25-INCH, 150 PSI PVC BALL VALVE, 200 PSI PVC TRUE UNION BALL CHECK VALVE, PVC FLEX HOSE WITH MINIMUM WORKING PRESSURE RATING OF 60 PSI, AND SCHEDULE 40 PVC PIPE.
- 4.4. THE PRESSURIZED **TRANSPORT PIPE** FROM THE DISCHARGE ASSEMBLY TO THE SOLENOID ZONE VALVES SHALL BE 1.5" SCHEDULE 40 HDPE PIPE WITH FUSION-WELDED JOINTS (THIS PIPE SHALL BE LABELLED ACCORDING TO CURRENT UPC REQUIREMENTS "RECLAIMED WATER - DO NOT DRINK").

5. SHALLOW PRESSURIZED DISPERSAL TRENCHES

- 5.1. A HIGH PRESSURE GATE VALVE AT THE HEAD OF EACH TRENCH SHALL BE INSTALLED IN ORDER TO DISTRIBUTE TREATED EFFLUENT EVENLY TO EACH OF THE DISPERSAL TRENCHES.
- 5.2. PRIMARY AND SECONDARY DRAINFIELDS EACH CONSISTING OF CHAMBERED DISPERSAL TRENCHES. TRENCHES SHALL BE 3'-WIDE, 4.5'-DEEP AND OF VARYING LENGTHS. EACH DRAINFIELD SHALL CONSIST OF A 288 LINEAR FEET OF TRENCH (72 QUICK4 PLUS HIGH-CAPACITY INFILTRATOR CHAMBERS) FOR A COMBINED TOTAL OF 576 LINEAR FEET OF TRENCH (144 QUICK4 PLUS HIGH-CAPACITY INFILTRATOR CHAMBERS). TRENCHES SHALL BE INSTALLED IN THE GENERAL LOCATION SHOWN ON THE PLAN. THE FLOOR OF EACH TRENCH SHALL BE LEVEL. INSTALLER TO SCARIFY TRENCH WALLS TO REMOVE SMEAR AND INCREASE SURFACE AREA FOR ABSORPTION.
- 5.3. INSTALLER SHALL ASSURE THAT SURFACE DRAINAGE IS DIRECTED AWAY FROM THE FINISHED DISPERSAL TRENCHES.
- 5.4. THE PIPING FROM THE PUMP TANK TO THE DISPERSAL TRENCHES SHALL BE 1.5" SCH40 PVC.
- 5.5. THE LEACHFIELD PRESSURIZED PIPE SHALL BE 1" SCH40 PVC WITH 1/8" ORIFICES SPACED 5 FT APART.
- 5.6. ALL PRESSURIZED PIPING SHALL BE SCH40 PVC AND LABELLED ACCORDING TO CURRENT UPC REQUIREMENTS "TREATED WASTEWATER - DO NOT DRINK". PRESSURE PIPING SHALL BE PRESSURE-RATED TO 150 PSI AND SOLVENT WELDED.
- 5.7. CONCRETE THRUST BLOCKS, OR EQUIVALENT RESTRAINT, SHALL BE PROVIDED AT SHARP CHANGES IN PIPING DIRECTION.
- 5.8. DRAINFIELD SHALL MEET SANTA CLARA COUNTY GUIDELINES FOR TREE PROTECTION AND PRESERVATION FOR LAND USE APPLICATIONS.

6. INSTALLER QUALIFICATIONS AND RESPONSIBILITIES

- 6.1. THE SYSTEM INSTALLER SHALL BE LICENSED BY THE STATE OF CALIFORNIA, DEPARTMENT OF CONSUMER AFFAIRS, TO INSTALL SEPTIC SYSTEMS. INSTALLER CERTIFICATION IS REQUIRED BY THE LOCAL ADVANTEX™ DEALER. THE INSTALLER IS REQUIRED TO FULLY READ AND UNDERSTAND THE ADVANTEX™ AND GEOFLOW MANUALS PRIOR TO THE COMMENCEMENT OF WORK.
- 6.2. ALL PIPING SHALL CONFORM TO THE CURRENT EDITION OF THE PLUMBING CODE.
- 6.3. THE INSTALLER SHALL BE RESPONSIBLE FOR LOCATING ANY PROPERTY LINES, UNDERGROUND UTILITIES OR PIPING. ANY DAMAGE TO THESE FACILITIES SHALL BE THE RESPONSIBILITY OF THE INSTALLER.
- 6.4. A PRE-CONSTRUCTION CONFERENCE WITH DESIGNER, INSPECTOR AND DEALER/SERVICE PROVIDER SHALL BE ARRANGED PRIOR TO THE COMMENCEMENT OF WORK. PRE-CONSTRUCTION CONFERENCE SHOULD INCLUDE CONSTRUCTION PROCEDURES, STAKING OR MARKING OF THE VARIOUS SYSTEM COMPONENTS TO BE PROVIDED. CONSTRUCTION INSPECTIONS, WATERTIGHT TANK TEST INSPECTION, ADVANTEX™ INSTALLATION INSPECTION, AND FINAL OPERATION OF SYSTEM SHALL BE MADE BY DESIGNER (BIOSPHERE CONSULTING) OR LOCAL DISTRIBUTOR AND SYSTEM SERVICE PROVIDER AND THE COUNTY OF SANTA CLARA DEPARTMENT OF ENVIRONMENTAL HEALTH (408-918-3400). CONSTRUCTION INSPECTION SHOULD INCLUDE INSPECTION OF THE FOLLOWING: WATER TIGHTNESS OF SEPTIC TANK AND DOSING (PUMP) TANK, LAYOUT AND EXCAVATION OF DISPERSAL TRENCHES AND PIPING, DRAIN ROCK MATERIAL AND PLACEMENT, PIPING INSTALLATION AND HYDRAULIC ("SQUIRT") TEST OF THE DISTRIBUTION SYSTEM, FUNCTIONING AND SETTING OF ALL CONTROL DEVICES. FINAL INSPECTION TO VERIFY THAT ALL CONSTRUCTION ELEMENTS ARE IN CONFORMANCE WITH THE APPROVED PLANS AND SPECIFICATIONS. ALL PERFORMANCE WELLS ARE INSTALLED; AND EROSION CONTROL HAS BEEN COMPLETED. THE INSTALLER SHALL GIVE AT LEAST 48 HOURS NOTICE TO EACH PARTY FOR ALL INSPECTIONS. DESIGNER SHALL PROVIDE FINAL INSTALLATION APPROVAL LETTER AND AS-BUILT DRAWINGS PER DEH REQUIREMENTS.

7. ELECTRICAL WORK

- 7.1. THE VERICOMM® CONTROL PANEL WITH LOGO SCREEN AND 110 OUTLET SHALL BE INSTALLED IN THE LOCATION SHOWN ON THE MAP **WITH THE BOTTOM OF THE PANEL BOX AT 51" FROM THE GROUND SURFACE.**
- 7.2. ONE, 20 AMP, 120V ELECTRICAL CIRCUIT AND TWO, 20 AMP, 230V ELECTRICAL CIRCUITS SHALL BE EXTENDED TO THE VERICOMM® PANEL IN A SINGLE CONDUIT. UNDERGROUND CIRCUITS IN SEPARATE CONDUITS SHALL BE INSTALLED FROM THE PANEL TO THE RECIRCULATION PUMP AND DISCHARGE PUMP. A SEPARATE UNDERGROUND CONDUIT CONTAINING A LIVE CAT5 PHONE LINE SHALL BE INSTALLED TO THE VERICOMM® PANEL. THE SYSTEM WILL NOT BE FINALIZED UNTIL EVERYTHING (INCLUDING PANEL TELEMETRY) IS FUNCTIONAL.
- 7.3. ALL WORK SHALL CONFORM TO THE CALIFORNIA ELECTRICAL CODE AND THE CONTRACTOR SHALL BE RESPONSIBLE FOR OBTAINING ANY ELECTRICAL PERMITS REQUIRED.

8. SITE CLEAN UP AND EROSION CONTROL MEASURES

- 8.1. ALL EXCAVATED AREAS SHALL BE SMOOTHED AND ALL CONSTRUCTION DEBRIS SHALL BE REMOVED FROM THE SITE.
- 8.2. ALL DISTURBED SOILS SHALL BE SEEDED AND MULCHED. EROSION CONTROL MIX SEED SHALL BE USED AT THE COVERAGE RECOMMENDED ON THE PACKAGE FOR ALL DISTURBED SOIL.
- 8.3. STRAW SHALL BE USED TO COVER ALL DISTURBED SOIL.
- 8.4. PER DIVISION C12, CHAPTER III OF THE COUNTY CODE (SEC. C12-513. TEMPORARY EROSION CONTROL.) "THE PERMITTEE AND ANY PERSON(S) DOING, CAUSING OR DIRECTING THE GRADING SHALL INSTALL AND MAINTAIN ALL PRECAUTIONARY MEASURES NECESSARY TO PROTECT ADJACENT WATERCOURSES AND PUBLIC OR PRIVATE PROPERTY FROM DAMAGE BY EROSION, FLOODING, OR DEPOSITION OF MUD OR DEBRIS ORIGINATING FROM THE SITE. PRECAUTIONARY MEASURES MUST INCLUDE PROVISIONS OF PROPERLY DESIGNED EROSION PREVENTION AND SEDIMENT CONTROL MEASURES, SO THAT DOWNSTREAM PROPERTIES ARE NOT AFFECTED BY UPSTREAM EROSION OR SEDIMENT TRANSPORT BY STORMWATER."

9. OPERATING PERMIT FOR ALTERNATIVE OWTS

- 9.1. IN ADDITION TO THE INSTALLATION PERMIT, AN OPERATING PERMIT IS REQUIRED FOR ALTERNATIVE OWTS PER SECTION B11-92 OF THE SANTA CLARA COUNTY ORDINANCE.
- 9.2. THE OPERATING PERMIT WILL BE ISSUED AFTER COMPLETION OF THE SEPTIC SYSTEM INSTALLATION AND FINAL INSPECTION.
- 9.3. THE OPERATING PERMIT IS SUBJECT TO RENEWAL, FEES AND WILL BE RECORDED ON THE DEED TO THE PROPERTY BY THE COUNTY RECORDER OF SANTA CLARA COUNTY.

GENERAL NOTES

1. ALL NOTES FOUND IN THESE DOCUMENTS SHALL APPLY TYPICALLY THROUGHOUT. IF INCONSISTENCIES ARE FOUND IN THE VARIOUS NOTATIONS, NOTIFY THE DESIGNER (BIOSPHERE CONSULTING, INC.) IMMEDIATELY REQUESTING CLARIFICATION. PLAN CHANGES OR SPECIFICATIONS SHALL BE MADE ONLY AFTER CONSULTATION WITH AND APPROVAL BY THE DESIGNER.

2. ALL WORK SHALL COMPLY WITH APPLICABLE CODES AND TRADE STANDARDS WHICH GOVERN EACH PHASE OF WORK INCLUDING, BUT NOT LIMITED TO, CALIFORNIA PLUMBING CODE, MECHANICAL CODE, ELECTRICAL CODE AND ALL APPLICABLE STATE AND/OR LOCAL CODES.

3. THE INSTALLER IS REQUIRED TO FULLY READ AND UNDERSTAND THE MANUFACTURERS INSTALLATION MANUALS PRIOR TO THE COMMENCEMENT OF WORK.

4. ALL SPECIFIED EQUIPMENT SHALL BE INSTALLED IN STRICT ACCORDANCE TO THE MANUFACTURERS INSTALLATION GUIDELINES/REQUIREMENTS. TANK INSTALLATION SHALL INCLUDE ANTI-BOUYANCY/FLOATATION MEASURES (CONCRETE COLLARS) ACCORDING TO MANUFACTURES REQUIREMENTS.

5. IT IS CRITICALLY IMPORTANT THAT ALL TANKS SHALL BE MADE WATERTIGHT TO THE GROUND SURFACE AND DEMONSTRATED TO BE WATERTIGHT PRIOR FINAL SIGN-OFF.

6. IT IS THE RESPONSIBILITY OF THE CONTRACTOR AND ALL SUBCONTRACTORS TO CHECK AND VERIFY ALL CONDITIONS, DIMENSIONS, LINES AND LEVELS INDICATED. PROPER FIT AND ATTACHMENT OF ALL PARTS IS REQUIRED. SHOULD THERE BE ANY DISCREPANCIES, IMMEDIATELY NOTIFY THE DESIGNER (BIOSPHERE CONSULTING, INC.) FOR CORRECTION OR ADJUSTMENT.

7. THROUGHOUT THIS PLAN SET THE TERM "OR APPROVED EQUAL" MAY BE USED. THIS TERM "APPROVED EQUAL" SHALL MEAN EQUAL IN THE JUDGMENT OF THE DESIGNER. THE BIDDER, AS A SUPPLEMENT TO THE BASE BID, MAY SUBMIT ALTERNATE PROPOSALS FOR PRODUCTS, SYSTEMS OR PROCEDURES NOT SPECIFIED FOR CONSIDERATION BY OWNER AND DESIGNER. ALTERNATE PROPOSALS WILL BE CONSIDERED ONLY IF BIDDER HAS SUBMITTED A BASE BID, WHICH IS IN ACCORDANCE WITH THE REQUIREMENTS OF THE SPECIFICATIONS. SHOULD THE BIDDER SEEK APPROVAL OF A PRODUCT OTHER THAN THE BRAND OR BRANDS NAMED IN THE SPECIFICATIONS, IT SHALL FURNISH WRITTEN EVIDENCE THAT SUCH PRODUCT CONFORMS IN ALL RESPECTS TO THE SPECIFIED REQUIREMENTS, AND THAT IT HAS BEEN USED SUCCESSFULLY ELSEWHERE UNDER SIMILAR CONDITIONS. WHERE THE SPECIFIED REQUIREMENTS INVOLVE CONFORMANCE TO RECOGNIZED CODES OR STANDARDS, THE BIDDER SHALL FURNISH EVIDENCE OF SUCH CONFORMANCE IN THE FORM OF TEST OR INSPECTION REPORTS, PREPARED BY A RECOGNIZED AGENCY, AND BEARING AN AUTHORIZED SIGNATURE. MANUFACTURER'S STANDARD DATA AND CATALOG CUT SHEETS WILL NOT BE CONSIDERED SUFFICIENT IN THEMSELVES, AND THE DESIGNER WILL NOT BE RESPONSIBLE FOR SEEKING FURTHER DATA FROM THE MANUFACTURER, OR FOR OTHERWISE RESEARCHING THE PRODUCT. FAILURE TO PROVIDE COMPLETE DATA WILL BE CAUSE FOR REJECTION OF THE PROPOSED ALTERNATE PRODUCT. THE SUBMISSION SHALL INCLUDE ANY IMPACTS THAT COULD BE EXPECTED FROM THE ALTERNATIVE PRODUCT AND SHALL ALSO INDICATE ANY PRODUCT THAT WOULD REQUIRE A LICENSE OR ROYALTY, THE ACTUAL FEES, AND A NOTE THAT THESE FEES WOULD BE HANDLED BY THE BIDDER. OWNER AND/OR DESIGNER RESERVES THE RIGHT TO ACCEPT OR REJECT BIDDERS ALTERNATE PROPOSALS.

8. THE SPECIFIED COMPONENTS SHALL BE INSTALLED BY A LICENSED CONTRACTOR EXPERIENCED IN THE INSTALLATION OF ADVANTEX® PRODUCTS. CONTRACTORS SHALL BE CERTIFIED BY ORENCO SYSTEMS, INC., OR AN AUTHORIZED DEALER AS AN "AUTHORIZED ADVANTEX INSTALLER" AND SHOW EVIDENCE OF SUCCESSFULLY INSTALLING AT LEAST THREE ADVANTEX® SYSTEMS IN ACCORDANCE WITH THE MANUFACTURER'S RECOMMENDATIONS AND THE DESIGN PLANS. A DETAILED SUMMARY OF THESE PROJECTS INCLUDING THE PROJECT NAME, ADDRESS AND ADVANTEX® DEALER REPRESENTATIVE FOR THE PROJECT MAY BE REQUESTED.

9. COMMENCEMENT OF WORK BY THE CONTRACTOR AND/OR ANY SUBCONTRACTOR SHALL INDICATE KNOWLEDGE AND ACCEPTANCE OF ALL CONDITIONS DESCRIBED IN THESE CONSTRUCTION DOCUMENTS.

10. A PRE-CONSTRUCTION SITE CONFERENCE WITH DESIGNER SHALL BE ARRANGED PRIOR TO THE COMMENCEMENT OF WORK. REGULAR CONSTRUCTION INSPECTIONS, WATERTIGHT TANK TEST INSPECTION, ADVANTEX INSTALLATION INSPECTION, AND FINAL OPERATION OF SYSTEM SHALL BE MADE BY DESIGNER (BIOSPHERE CONSULTING) OR LOCAL DEALER WITH THE COUNTY OF SANTA CLARA DEPARTMENT OF ENVIRONMENTAL HEALTH INSPECTOR PRESENT. THE INSTALLER SHALL GIVE AT LEAST 24-HOURS NOTICE TO THE DESIGNER AND DEH FOR ALL INSPECTIONS REQUESTED.

11. INSTALLATION OF ALL GRAVITY FLOW SANITARY SEWER LINES SHALL BE FULLY COORDINATED WITH PLUMBING CONTRACTOR RESPONSIBLE FOR INTERNAL PLUMBING IN /UNDER STRUCTURES.

12. CONTRACTOR SHALL BE RESPONSIBLE FOR PROVIDING AND INSTALLING ALL INCIDENTAL MATERIALS REQUIRED FOR A COMPLETE INSTALLATION. MATERIALS AND EQUIPMENT SHALL BE U.L. LISTED AND LABELED FOR THE APPLICATION.

14. ALL ELECTRICAL WORK SHALL CONFORM TO THE CURRENT NATIONAL ELECTRICAL CODE AND SHALL BE PERFORMED UNDER PERMIT AND INSPECTION FROM THE COUNTY BUILDING DEPARTMENT. INSTALLATION CONTRACTOR IS RESPONSIBLE FOR ASSURING THAT THE CONTROL PANEL INCLUDING PHONE/DATA LINE WITH CAT5 WIRING IS INSTALLED AND FULLY FUNCTIONAL TELEMETRY CONNECTION SHALL BE DEMONSTRATED PRIOR TO FINAL APPROVAL SIGN-OFF.

COUNTY E.H. ACCEPTANCE/APPROVAL STAMPS



BioSphere Consulting

Incorporated

- Site Evaluation & Mapping
- Soil Analysis & Percolation Testing
- New Development, Upgrade & Repairs
- Residential & Commercial

Alternative Wastewater System Design

www.biosphere-consulting.com

1315 King Street
Santa Cruz, CA 95060
Tel: (831) 430-9116

ONSITE WASTEWATER TREATMENT SYSTEM DESIGN PLAN

| | | | |
|---------------------------|---|------------------------|---------------|
| Project Location: | 0 Piercy Road in San Jose, California, [Santa Clara County] | | |
| Property Owner: | Southridge Church C/o: Micaiah Imler | | |
| Mailing Address: | 6830 Via Del Oro, Suite 250 San Jose, CA, 95119 | | |
| Owner Phone #: | (408) 728-7471 | | |
| Date: 03/08/23 | By: David Quinn / Andrew Brownstone | Sheet: | |
| REVISION: 10/30/23 | Job No.: 22021 | APN: 678-13-012 | 3 OF 3 |

